

Feb. 28, 1961

A. J. DANIELSEN, JR., ET AL
ROOF TRUSS ASSEMBLING APPARATUS

2,973,022

Filed April 7, 1959

2 Sheets-Sheet 1

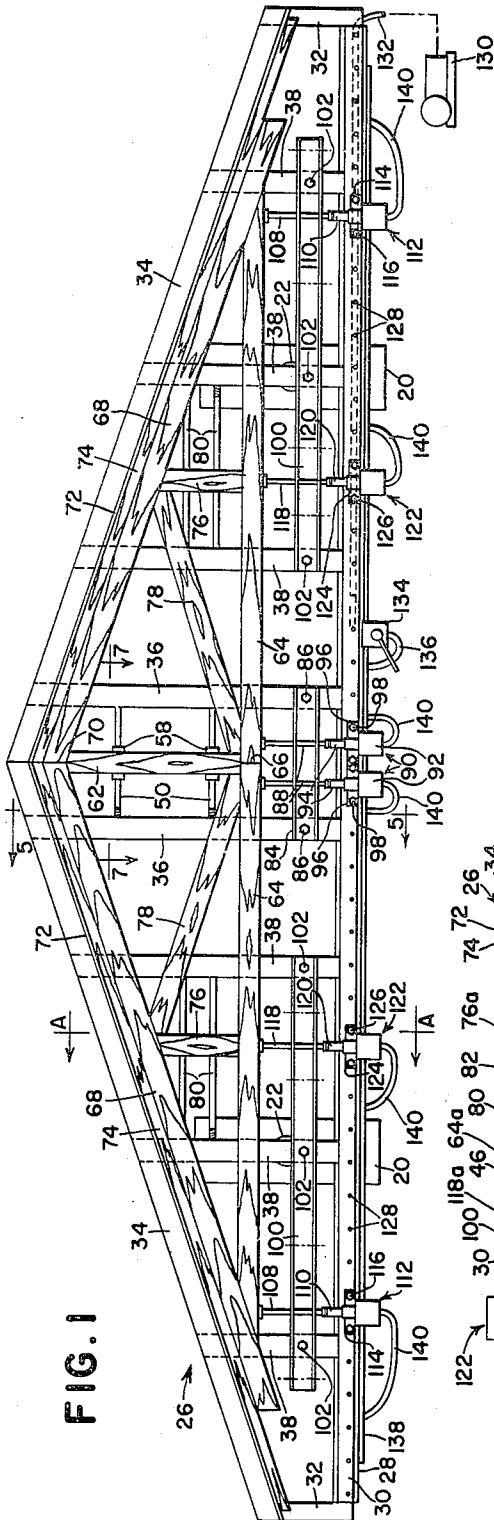

FIG. 1

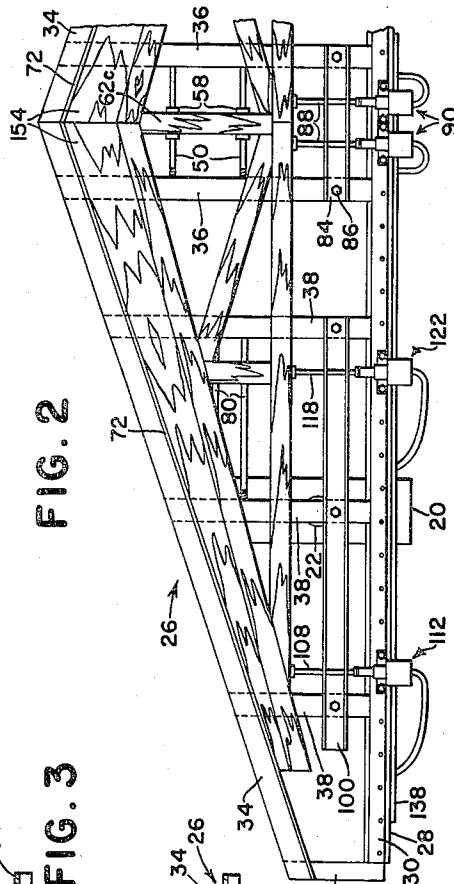

FIG. 2

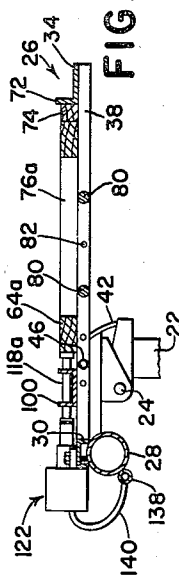

FIG. 3

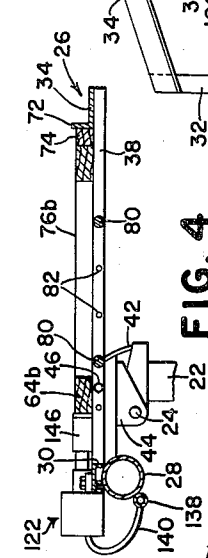

FIG. 4

INVENTORS
A. J. DANIELSEN, Jr.
R. C. SCHNECKLOTH

BY

[Signature]

ATTORNEY

1

2,973,022

ROOF TRUSS ASSEMBLING APPARATUS

Alfred J. Daniels, Jr., Bettendorf, and Raymond C. Schnecko, Clinton, Iowa, assignors to Bettendorf Distributing Co., Bettendorf, Iowa, a corporation of Iowa

Filed Apr. 7, 1959, Ser. No. 804,829

6 Claims. (Cl. 144-288)

This invention relates to an apparatus for assembling roof trusses from prefabricated components and has for its principal object the provision of an improved apparatus capable of expediting the mass-production of roof trusses and similar structures.

It has long been conventional practice to assemble roof trusses from prefabricated components by laying them on a table or the like having stops, abutments and other gauging means to establish the pattern of the truss, the several components meeting in butt joints and subsequently secured by appropriate fasteners, the most popular of which are perforated sheet metal plates nailed to the truss components. Since the partially assembled and nailed truss is supported on a table, nailing can be accomplished from only one side, and it is thereafter necessary to remove the truss, reverse it and place it again on the table so that nailing may be accomplished from the other side. This obviously has many disadvantages, since the truss in its pre-nailed condition is subject to racking, twisting and other distortion, and consequently much of the accuracy of the pattern is lost. As a means for improving this situation, apparatus was subsequently developed of the type enabling reversal of the truss without removing it from the table or support. However, such apparatus involves undesirable complications and expense and furthermore requires that nailing be done with the truss in horizontal positions, which makes it difficult for the workman to reach interior fastening zones.

According to the present invention, these and other disadvantages are eliminated by the provision of a truss-assembling apparatus comprising basically a jig frame on which the truss may be assembled in a predetermined pattern, together with means on the jig frame for compressing the truss components to retain the pattern while same is being fastened. Moreover, the jig frame is mounted on support means including a horizontal pivot axis about which the jig frame as a whole may be swung from a horizontal assembling position to an upright nailing position. The jig frame is of open-work construction so as to afford access to the truss components from both sides. This speeds up production, because the workmen may stand comfortably at either side in positions enabling them to reach all fastening zones.

The invention has for another significant object the provision of force-exerting means operable on the truss components to compress and clamp same in assembled relation, the force-exerting means being arranged as a number of individual force-exerting devices properly placed with respect to the struts, braces, chords, etc. of the truss. Further objects of the invention reside in adjustable mounting of the force-exerting devices so as to accommodate trusses of different sizes; the provision for adjustability of the jig frame components so as to accommodate trusses not only of different sizes but of different pitches; novel bracket and guide means for force-applying parts operated by the force-exerting means; and adjustable and replaceable jig frame components capable

2

of being selectively positioned according to the types and sizes of trusses being handled.

The foregoing and other important objects and desirable features inherent in and encompassed by the invention thereof will become apparent as a preferred embodiment thereof is disclosed in detail in the ensuing description and accompanying sheets of drawings, the figures of which are described below.

Figure 1 is a plan view of the apparatus with a truss assembled thereon.

Figure 2 is a fragmentary plan view showing the use of certain adjustments in the apparatus for accommodating a truss having a different pitch.

Figure 3 is a sectional view as would be seen along the line *a-a* of Figure 1 but illustrating an adjustment in the apparatus for accommodating a truss having a different altitude.

Figure 4 is a similar sectional view showing the adaptability of the apparatus to a truss of a still higher altitude.

Figure 5 is a section as seen on the line 5-5 of Figure 1.

Figure 6 is a perspective of the apparatus, with the truss assembled thereon, shown in its upright position to illustrate how workmen may operate thereon from both sides.

Figure 7 is an enlarged section as seen generally along the line 7-7 of Figure 1.

Figure 8 is an enlarged fragmentary sectional view showing the application of a force-transmitting part to the piston of one of the force-exerting devices.

Figure 9 is a section on the line 9-9 of Figure 8.

Figure 10 is an enlarged section on the line 10-10 of Figure 5.

The apparatus is preferably ground- or floor-supported and for that purpose it has a pair of floor-based supports or pedestals 20, each of which includes a rigid standard 22 having an upper end providing a horizontal pivot pin 24. These pins are horizontally coaxial and will hereinafter be referred to as the horizontal pivot axis on which a jig frame, designated in its entirety at 26, is mounted for movement between a generally horizontal position as shown in Figures 1, 3, 4 and 5 and a generally upright position as shown in Figure 6.

The jig frame is made up of a plurality of elements, one of which is preferably an elongated tubular base element 28 to the upper surface portions of which is welded a parallel inverted channel element 30. Opposite end arm elements 32 are welded to the ends of the element 28 and project radially therefrom to support at their free ends a pair of angle elements 34 which meet at the apex of the generally isosceles triangle formed by the jig frame. The several elements are appropriately rigidly interbraced by a plurality of brace bars, including a central pair 36 and two sets of shorter outer bars 38, one set at each side of the center line of the frame.

The center bar 38 of each of the outer sets has means thereon for mounting the jig frame on the pivot axis 24-24 so that the jig may swing from a horizontal to an upright position and return. The location of the pivot axis 24-24 relative to the weight of the jig frame and truss assembled thereon is significant from the standpoint that it is so placed as to facilitate swinging of the jig frame between the two positions just noted. Moreover, the pivot is located so that when the jig frame is in its upright position, the weight passes over center as respects the axis, thus serving as means for retaining the jig frame in a stable upright position. When the frame is in its horizontal position, it is limited against further downward swinging by a pivoted leg 40 (Figures 5 and 6) and additionally by stop means 42 cooperative between the upper sides of the standards 22 and the under side of the jig frame 26. The structure in a specific

sense is significant because it provides means for adjusting the axis 24 relative to the weight of the jig frame, thereby enabling variations in location. An exemplary construction is shown in the drawings, particularly Figure 10, wherein it will be noted that the bar 38 is of channel cross section and carries slidably lengthwise therein a block 44 which has depending ears received by the proximate pin 42. Adjustability of the block 44 lengthwise of the channel 38 results from the slidable association of the two, and any selected adjusted position may be maintained by appropriate securing means, such as a set screw 46. When the frame is in its horizontal or down position, it is stably supported because of the stops at 42, 42 in conjunction with the floor-contacting leg 40. The pivotal mounting of the leg 40 to the jig frame at a pivot 48 assures that the leg will swing toward the frame and thus be out of the way when the frame is in its upright position.

In the upright position of the frame, the pipe 28 contacts the backs of the standards 22 so as to afford a limiting stop. Since the weight of the frame passes over-center as respects the axis 24—24, the stable upright position is assured. Of course, the position can be manually over balanced to return the jig frame to its horizontal position. This, plus the location of the pivot axis 24—24 relative to the distributed weight of the frame and assembled truss makes the apparatus extremely easy to handle. As respects the specific location of this axis, it should be noted that it is below the level of the frame and downwardly and forwardly of the tube 28 in such amounts as to make possible the two characteristics just noted.

The open-work frame structure 26 is accomplished preferably by welding the various components together so as to assure a rigid construction. However, some of the parts may be adjustable as equivalents of means to be presently described. For present purposes, the rigidity secured by welding will be assumed; although, it will be recognized that different types of connections may be utilized where equivalent adjusting mechanism is desired. Since the open-work nature of the frame renders the frame skeletal, ready access to the frame may be had from both sides. On the other hand, the components just described do not in all cases support all elements or members of the truss, and for this purpose some of the members are supplemented by additional supports. For example, the center set of bars 36, 36 is supplemented by a pair of cross members or rods or cross bars 50, each of which, as best shown in Figure 7, has reduced ends in the form of pintles 52, and one of the pintles is equipped with a compression spring 54 so that the bar 50, being longer than the space between the bars 36, can be shortened in length by manually shifting the bar against the spring 54 so as to enable withdrawal of the pintle 52 at the opposite end from a pintle-receiving hole 56 in the bar 36. As best seen in Figure 6, each of the bars is provided with a plurality of holes 56 so that the cross bars 50 may be selectively positioned lengthwise thereof. See also Figures 3 and 4. As best shown in Figure 7, each of the rods or bars 50 may have adjustable means thereon, for purposes to presently appear. A preferred form of a adjustable means may comprise a pair of collars 58 releasably retained in place as by set screws 60.

The description of further features of the jig frame will be postponed until typical truss structures are described. The truss shown in Figure 1 is of conventional construction as respects size, shape and number of components and has a 4—12 pitch established by an altitude or center strut 62 which extends between bottom and top chords. The bottom or base chord is made up of a pair of bottom chord elements 64 arranged in end-to-end relation and having their inner ends butted together at 66. The opposite outer ends of the members 64 are appropriately cut off to abut the bottom or outer ends

of a pair of top chord members 68. These members meet at a butt joint 70 at the apex of the isosceles triangle formed thereby, and the strut 62 is shaped at opposite ends to act in compression between the butt joints 66 and 70. Since the strut 62 lies on the altitude of the triangle, it will overlap the two butt joints as noted in Figure 1. The truss is symmetrical, of course, at opposite sides of the altitude of the isosceles triangle and the members 64 are of course of equal length. The members 68 are longer than the members 64 but are of equal length as respects each other.

Another characteristic of the truss shown by way of example is that its components are conventional dimensional lumber, here 2 x 4's. When the truss components are laid upon the jig frame in its horizontal position, at which time it may be regarded somewhat as a table, the pattern of the truss is set by components of the jig frame. The members 34 of the frame, previously described as angle members, have their upright flanges 72 disposed to form abutment means lying along the outer edges of the top chord members 68. Since these members are here shown as 2 x 4's, a wooden filler strip 74 may be used in conjunction with each flange 72 to supplement the abutment elements or means. If the top chord were constructed of a pair of 2 x 6's, then the filler strip 74 could be removed. Any type of fastening means may be utilized to retain the filler strips 74 releasably in place. These details do not import any limitations into the present invention. As indicated above, the result accomplished by the adjustability flowing from use of the filler strips 74 may be achieved also by adjusting the angles 34 lengthwise of the bars 36 and 38. However, the rigid construction secured by welding, plus the use of the removable filler strips 74, is deemed preferable in the interests of maintaining adequate rigidity in the structure.

The function of the stop collars 58 on the cross bars 50 will be best perceived from Figures 1, 6 and 7, wherein it will be noted that the center or altitude strut 62 is gauged or located by these collars, whereby this strut is exactly centered on the altitude of the triangle and therefore is centered on the two butt joints 66 and 70. Here again, the use of truss components in the form of 2 x 6's can be accommodated, since the collars 58 may be spaced more widely apart.

The truss, being conventional, is completed by the use of a pair of shorter outer struts 76 and a pair of diagonal braces 78. Each outer strut extends in compression between an intermediate portion of a bottom chord member 64 and an intermediate portion of the corresponding top chord member 68. The diagonal brace 78 extends at its inner end from the junction of the center strut 62 with the base member 64 to a junction at its outer end with the junction between the outer strut 76 and the associated top chord member 68. As is true in typical construction, the ends of the struts and braces are appropriately shaped. These are all prefabricated by any suitable mass-production method so that they will accurately follow the assembled pattern when placed on the horizontally positioned jig frame or table 26. The inner pairs of bars 38 of the outer sets are spanned by a pair of cross bars or rods 80 identical in structural details to the rods 50, except that the rods 80 do not have the adjustable stop collars 58. The associated bars 38 are each provided with a plurality of openings 82 (Fig. 6) so that the bars 80 may be adjusted lengthwise of the associated bars 38. As sizes and shapes of trusses assembled on the jig frame or table 26 vary, the positions and lengths of the struts and bases will accordingly vary. Consequently, the provision for adjustable positioning of the cross bars 50 and 80.

The jig frame includes means for applying compressive forces to the truss in horizontal planes and in the directions of the abutment elements or angles 34, and specifically in directions parallel to the truss struts 62 and 76. For this purpose, the center bars 36 are spanned

by a bracket or channel 84, rigidly but removably held in place by a pair of bolts 86. The flanges of the channels are appropriately apertured to carry a pair of slidable plungers or rods 88 spaced equidistantly to opposite sides of the altitude or center line of the truss and jig frame. Respectively aligned with the plungers 88 are a pair of force-exerting devices 90, each comprising a cylinder 92 and a piston 94, each device thus constituting a fluid-pressure-operated motor of the cylinder and piston type. These motors are identical and each is rigidly but removably mounted on the channel 30 of the base element 28 by means of brackets 96 and cap screws 98.

Each of the sets of outer bars 38 carries rigidly thereon a channel, guide or bracket 100 which is similar to but longer than the guide 84. The channel 100 is removably secured to the bars 38 as by bolts 102. Each channel has its flanges provided with sets of holes, comprising an inner set 104 and an outer set 106. Paired holes in each set are of course aligned crosswise of the channel and paired holes in the set 104 are adapted to slidably carry a plunger or rod 108 which may be identical to those described at 88. This rod, like those at 88, projects at one side of the bracket or guide 100 to engage the bottom chord member 64 adjacent to its junction with the associated top chord member 68, and the opposite end of the rod projects to the other side of the channel 100 for engagement by the piston 110 of a fluid motor 112 which may be identical to the motors 90. Each of the motors 112 is releasably secured in place as by brackets 114 and cap screws 116.

Aligned pairs of holes in the sets 106 slidably carry plungers 118 which are arranged identically with the plungers 108 and 88 as respects their functions and relations to the respective channels 100 and 84. These plungers or rods are powered by pistons 120 of fluid motors identical to the motors 90 and 112. Here again brackets 124 and cap screws 126 are used as releasable securing means for mounting the motors 122.

The motors 122 and 112, especially, may be adjusted lengthwise of the base element 28—30 for purposes of accommodating trusses of different sizes and construction, and for this purpose the channel 30, that is welded to the tube 28, is provided with a plurality of equally spaced tapped bores 128 for receiving the respective set screws of the motor-mounting brackets as the motors are adjusted. On the basis of the typical dimensions of trusses that can be assembled on the jig frame, and by way of example only, the dimensional characteristics involved in the adjustability of the motors 112 and 122 are as follows: The distance between the tapped bores 128 in the inverted channel 30 is six inches. The spacing between the holes 104 in each channel 100 is six inches. The spacing between the holes in each set 106 is twelve inches. For example, in a truss having a longer span, the positions of outer struts corresponding to the struts 76 would be laterally outwardly of the positions illustrated. Since it is desired that the plunger 118 contact the bottom chord member 64 at its junction with the strut 76, it is necessary that the motor 122 be adjusted to the left. In typical truss constructions in which span sizes progress by known increments, it is found that the shifting of the strut corresponding to the strut 76 will be on the order of six inches. Consequently, the cap screws 126 are removed so that the motor 122 may be placed on the base element and secured by the next leftward set of tapped bores 128. In a similar construction, the length of the bottom chord will be such that it is desired to place the outer motors 112 twelve inches to the left of the positions they occupy in Figure 1. Consequently, the cap screws 116 are removed to release the brackets 114 and the motors are repositioned by using a set of bores 128 corresponding to the desired new position. In each case, of course, the plungers 108 and 118 are removed from their aligned openings and reinserted in openings aligned with the new positions

of the motors. This adjustment is available at both ends of the jig frame, since, as already noted, the frame is obviously symmetrical at opposite sides of the altitude of the isosceles triangle formed thereby. In normal situations, it will not be necessary to adjust the positions of the center motors 90. For purposes of clarification, the additional positions of the rods 108 and 118 are illustrated in broken lines in Figure 1. In its broad aspects, the invention obviously contemplates adjustable means other than the specific type illustrated; although, the disclosed form has the advantage of presently commercial acceptance.

The fluid motors 90, 112 and 122 are powered by a pressure source, preferably an air compressor designated generally by the numeral 130. The high pressure line of the compressor is connected to a fluid conduit 132 which runs lengthwise and interiorly of one end of the tube 28 and is then brought exteriorly of the tube for connection to a control valve 134. The outlet side of the valve 134 is connected by a conduit 136 to a conduit in the form of a rigid pipe 138 which is suitably mounted on and externally of the tube 28. This conduit is closed at its opposite ends but is connected intermediate its ends in parallel to the several motors by means of a plurality of flexible fluid conduits such as hoses 140. The use of fluid-pressure-operated motors, and preferably in conjunction with the air compressor 130, affords suitable control of the compressive forces exerted against the truss, especially since the motors are connected to the pressure source in parallel. The individual rods 88, 118, and 108, engaging directly against the bottom chord members 64, rather than an interposed platen, applies adequate pressure to the localized points respectively in alinement with the parallel struts 62 and 76 and thus properly compresses the truss in its accurate pattern. Since the truss components are accurately prefabricated, the pattern will be achieved and retained as long as the valve 134 maintains pressure and does not exhaust the pressure. With the assembled truss thus compressed and clamped in position between the motors and the abutment elements 34—74, the entire unit may be swung to its upright position as shown in Fig. 6, at which time, suitable fasteners may be applied from both sides as illustrated. These fasteners preferably include perforated metal plates 142 and nails 144. This type of fastening is conventional and need not be described in detail.

One distinct advantage of the apparatus is its ability to handle trusses of different sizes. Figure 3 illustrates a phase of adjustability or accommodation for a truss having a higher altitude, here represented by an outer strut 76a and a bottom chord member 64a, it being noted that the member 64a is much closer to the channel 100 than is the corresponding relationship in Figure 1. For this purpose, the plunger 118 is removed and is replaced with a shorter plunger 118a. The same change is made of course as respects all plungers 88, 108 and 118. Since the assumed truss used in Figure 3 has a higher altitude, it will also have longer chords and consequently the position of the strut 76a will be to the left of that shown in Figure 1. However, this phase has been described above in connection with the repositioning of the rods 118 or 118a in others of the set of holes 104. The same is true, of course, of plungers that replace the plungers 108.

Figure 4 shows a situation in which a truss is used in which the altitude is so high as to require the removal of the channels 84 and 100, and, also, the side struts, as at 76b, will of course move outwardly, requiring shifting of the motors 122. In this case, the guiding functions of the channels disappear, but the pistons of the motors may be replaced with short attachment plungers, one of which is shown in general at 146 in Figure 4 and in detail in Figures 8 and 9. For this purpose, the pistons of the several motors, of which the piston 94 is chosen as

exemplary, are provided with annular grooves, such as that shown at 148 in Figures 8 and 9. Each plunger 146 may have a spring-loaded ball 150 in which a leaf spring 152 urges the captive ball 150 into engagement with the groove 148 when the plunger 146 is snapped in place. When it is desired to remove the plunger 146, the spring 152 is easily lifted to release the ball from the groove so that the plunger may be axially withdrawn from the associated piston. This arrangement is repeated, of course, for each of the several motors. It should be understood, of course, that any releasable connection may be used, that illustrated being only by way of example.

Figure 2 illustrates the use of the jig in assembling the truss similar to that in Figure 1 but having a 3-12 pitch, in which case the altitude strut 62c is considerably shorter so that the angles between the top and bottom chords are smaller than those in Figure 1. For this purpose, appropriately shaped and tapered filler members 154, preferably of wood, are used between the flanges 72 and the outer edges of the top chord members of the lower-pitch truss shown in Figure 2.

As already noted, the disclosure here is based upon a design that has proven commercial acceptance. Consequently, the details illustrated are those engineered for this result and aimed at the accomplishment of the objects noted above, notably the tiltability of the apparatus from the horizontal position to the upright position and return, plus the open-work nature of the frame so that nailing or equivalent fastening may be accomplished from both sides of the compressed truss when the jig table is in its upright position. Other features such as those residing in adjustability of the motors, substitution of plungers for the plungers 88, 108 and 118, plus the removability of the channels and the adaptation of the apparatus to trusses of different sizes and pitches are regarded as significant. All of these results may, of course, be achieved in different manners, as by providing for adjustment of the entire truss relative to the motors while leaving the motors in place. However, as indicated, these are deemed to be the full equivalents of the arrangements illustrated. Other variations will readily suggest themselves on the basis of the present disclosure and the important principles of the invention may be exploited, along with other objects and advantages thereof, without departing from the spirit and scope of the invention.

What is claimed is:

1. Apparatus for assembling a roof truss, comprising: a jig table initially positioned substantially horizontally and presenting upper coplanar support portions for receiving and supporting a plurality of separate roof truss members in a predetermined pattern; means on the table affording an elongated base element along one edge of said table; abutment elements on the table and spaced horizontally from the base element for engaging certain of the roof truss members; force-exerting means on the base element for engaging other of the truss members to apply horizontal compressive forces to said other of said members in the direction of the abutment elements to releasably clamp the members in said pattern; support means; means mounting the table on the support means on a pivot axis proximate to and paralleling the base element for upward swinging of the table and clamped truss to a generally upright position, said axis being offset from the base element in the direction of the abutment elements in such amount that the weight of the table and truss is distributed to both sides of said axis so as to facilitate swinging of the table and truss to said upright position, and said axis further being offset below the level of the base element so that as the table and truss swing to said upright position the weight thereof passes over-center as respects said axis whereby said upright position is maintained; means for adjusting the mounting means to selectively vary the position of the axis back and forth

relative to the abutment elements so as to vary the relationship of said axis to the weight of the table and truss; first stop means limiting downward swinging of the table to said horizontal position; second stop means limiting upward swinging of the table to said upright position; and said table having openings therein exposing the junctions of the truss members with each other from the underside of the table so that when the table and truss are in said upright position fasteners may be applied to the clamped members at said junctions and from both sides of the table.

2. Apparatus for assembling a roof truss, comprising: a jig table initially positioned substantially horizontally and presenting upper coplanar support portions for receiving and supporting a plurality of separate roof truss members in a predetermined pattern; means on the table affording an elongated base element along one edge of said table; abutment elements on the table and spaced horizontally from the base element for engaging certain of the roof truss members; force-exerting means on the base element for engaging other of the truss members to apply horizontal compressive forces to said other of said members in the direction of the abutment elements to releasably clamp the members in said pattern; support means; means mounting the table on the support means on a pivot axis proximate to and paralleling the base element for upward swinging of the table and clamped truss to a generally upright position, said axis being offset from the base element in the direction of the abutment elements in such amount that the weight of the table and truss is distributed to both sides of said axis so as to facilitate swinging of the table and truss to said upright position; means for adjusting the mounting means to selectively vary the position of the axis back and forth relative to the abutment elements so as to vary the relationship of said axis to the weight of the table and truss; first stop means limiting downward swinging of the table to said horizontal position; second stop means limiting upward swinging of the table to said upright position; and said table having openings therein exposing the junctions of the truss members with each other from the underside of the table so that when the table and truss are in said upright position fasteners may be applied to the clamped members at said junctions and from both sides of the table.

3. Apparatus for assembling a roof truss, comprising: a jig table initially positioned substantially horizontally and presenting upper coplanar support portions for receiving and supporting a plurality of separate roof truss members in a predetermined pattern; means on the table for releasably clamping the truss members in said pattern; support means; adjustable means mounting the table on the support means on a horizontal pivot axis for upward swinging of the table and clamped truss to a generally upright position adjustable to vary the position of said axis in a plane parallel to that of the horizontal table and back and forth relative to the support means so as to selectively vary the location of said axis relative to the weight of the table and truss; means for stopping the table in said upright position; and said table having openings therein exposing the junctions of the truss members with each other from the underside of the table so that when the table and truss are in said upright position fasteners may be applied to the clamped members at said junctions and from both sides of the table; and means for stopping the table in its horizontal position when returned thereto from said upright position.

4. Apparatus for assembling roof trusses of various sizes from prefabricated chord and strut members, comprising: a jig having coplanar surface portions for receiving a truss having an elongated chord and a strut perpendicular to and having one end abutting the chord; abutment means on the jig for engaging the truss at a portion thereof opposite to the abutting end of the strut; bracket means on the jig outwardly of and parallel to the

chord and having a plurality of holes therethrough on axes parallel to the strut and spaced lengthwise of the chord, one of said holes being alined with the strut and other holes being alined with positions of other struts; a force-transmitting member slidably received in said one hole and having one end at one side of the bracket means engageable with the chord and an opposite end at the other side of said bracket means, said member being removable from said one hole for selective receipt by any of the other holes; a force-exerting device having a jig-engaging mount and a movable force-applying part engageable with said opposite end of the force-transmitting member; and means for adjustably securing said mount to the jig at any of a plurality of selected positions spaced apart lengthwise of the chord on the order of the spacing of the bracket means holes for selective alinement of said part with said member.

5. The invention defined in claim 4, in which: said bracket means, together with its force-transmitting member, is removable from the jig to enable direct engagement of the movable part with a chord of a truss having a longer strut.

6. Apparatus for assembling roof trusses of various sizes from prefabricated chord and strut members, comprising: a jig frame having a plurality of frame elements affording coplanar surface portions for receiving truss chord members, a pair of said elements being perpendicular to one chord member and spaced apart to straddle a strut extending between the chord members; a pair

of cross bars spanning said pair of elements to support such strut; and means cooperative between said cross bars and said pair of elements for enabling adjustable positioning of the cross bars lengthwise of said pair of elements, a series of holes in and spaced apart lengthwise of said elements and end portions on said bars selectively receivable in alined holes, one end portion on each bar being spring-loaded to enable lengthwise shifting of the bar in an amount sufficient to disengage its ends from alined holes for reengagement with other alined holes.

References Cited in the file of this patent

UNITED STATES PATENTS

| | | | |
|----|-----------|------------------|---------------|
| | 856,416 | McLarty ----- | June 11, 1907 |
| 15 | 1,415,895 | Obermiller ----- | May 16, 1922 |
| | 1,810,995 | Woelk ----- | June 23, 1931 |
| | 2,174,670 | Sauerland ----- | Oct. 3, 1939 |
| | 2,212,421 | Henderson ----- | Aug. 20, 1940 |
| | 2,305,124 | Wilson ----- | Dec. 15, 1942 |
| 20 | 2,617,571 | Hart ----- | Nov. 11, 1952 |
| | 2,623,560 | Joseph ----- | Dec. 30, 1952 |
| | 2,626,643 | Kantzler ----- | Jan. 27, 1953 |
| | 2,662,565 | Le Vay ----- | Dec. 15, 1953 |
| 25 | 2,749,873 | Huffman ----- | June 12, 1956 |
| | 2,919,733 | Johnson ----- | Jan. 5, 1960 |

FOREIGN PATENTS

| | | |
|---------|---------------------|---------------|
| 407,641 | Great Britain ----- | Mar. 22, 1934 |
|---------|---------------------|---------------|